

CODE	ND1	ND2	S	L1	L2	L3	L	H1	H
27NTCE020	1/2" => 20 mm	1/2" => 20 mm	0.12	1.48	1.81	2.05	1.77	2.62	3.27
27NTCE025	3/4" => 25 mm	3/4" => 25 mm	0.12	1.48	1.81	2.24	1.97	2.70	3.43
27NTCE032	1" => 32 mm	1" => 32 mm	0.12	1.48	1.85	2.52	2.17	2.95	3.80
27NTCE040	1" 1/4" => 40 mm	1" 1/4" => 40 mm	0.15	1.73	2.13	2.91	2.62	3.31	4.37
27NTCE050	1" 1/2" => 50 mm	1" 1/2" => 50 mm	0.18	1.83	2.40	3.35	3.01	3.94	5.26
27NTCE063	2" => 63 mm	2" => 63 mm	0.23	2.24	2.68	3.90	3.54	4.53	6.14
27NTCE075	2" 1/2" => 75 mm	2" 1/2" => 75 mm	0.27	2.28	2.83	4.41	3.86	5.12	7.01
27NTCE110	4" => 110 mm	4" => 110 mm	0.39	3.27	3.48	6.16	5.67	6.97	9.72
27NTCE160	6" => 160 mm	6" => 160 mm	0.57	3.42	4.13	7.93	5.94	8.19	11.93
27NTCE200	8" => 200 mm	8" => 200 mm	0.72	4.53	4.53	9.84	7.68	9.65	14.76

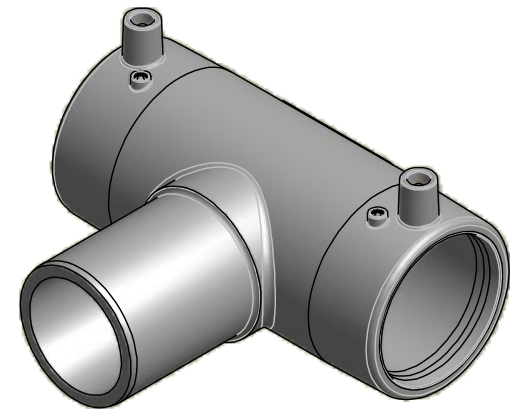

**NIRON**



ITEM: **NTCE**

DESC: ELECTROFUSION TEE  
SDR 11



DRAWING No:  
**NI10200**

SHEET OF	REV.
1 1	-1

www.nupiamericas.com - info@nupiamericas.com

All dimensions have to be considered in inches with 5% tolerance if not otherwise mentioned excluding values as per standard ASTM F2389